



**2004 State Competition**  
**FFA Agricultural Mechanics Contest**  
**University of Missouri**  
**50 points**

**Contestant #** \_\_\_\_\_  
**Contestant Name** \_\_\_\_\_  
**Chapter** \_\_\_\_\_

## Oxy-Acetylene

**Problem:**

This activity will require you to make a hanger for a 3/4" ID steel pipe. Two corners will need to be rounded to prevent injury after installation is complete. A 1/2" bolt will be used to hang the pipe, so a 2" x 1/2" slot will need to be cut to facilitate installation. Cut straight down through the metal, cut out the circle free handed for the 3/4" ID steel pipe, and cut the 1/2" slot for the 1/2" bolt.

**Materials:**

1. 1/4 inch x 3 inch x 4 inch hot rolled steel
2. Cutting attachment
3. Striker
4. Chipping hammer
5. Wire brush
6. Combination square
7. Pliers
8. Soapstone
9. 1/2" bolt & 3/4" ID pipe

**Directions:**

1. Secure metal from contest official.
2. Use soapstone and combination square to mark cut locations. (use diagram on next page)
3. Cut hole for 3/4" ID steel pipe as indicated.
4. Make rounded cut on end as indicated.
5. Cut the 1/2" x 2" slot for the 1/2" bolt.
6. Cool metal thoroughly.
7. Clean cuts with chipping hammer and wire brush.
8. Use masking tape provided to tape scorecard to metal.
9. Submit metal and this sheet to contest official.

**Evaluation Criteria**

Evaluation Criteria	Points Possible	Points Earned
1. Hole positioned properly.	5	_____
2. Hole fits 3/4" ID steel pipe.	5	_____
3. Plate is rounded properly.	5	_____
4. 1/2" x 2" slot fits a 1/2" bolt	5	_____
5. Uniformity.	5	_____
6. Use of correct flame type.	5	_____
7. Safety, work habits.	4	_____
8. Points from ID and general questions.	<u>16</u>	_____
<b>Total Points</b>	<b>50</b>	<div style="border: 1px solid black; width: 100px; height: 20px; margin: 0 auto;"></div>

Note: The areas that are shaded will be removed from the plate.

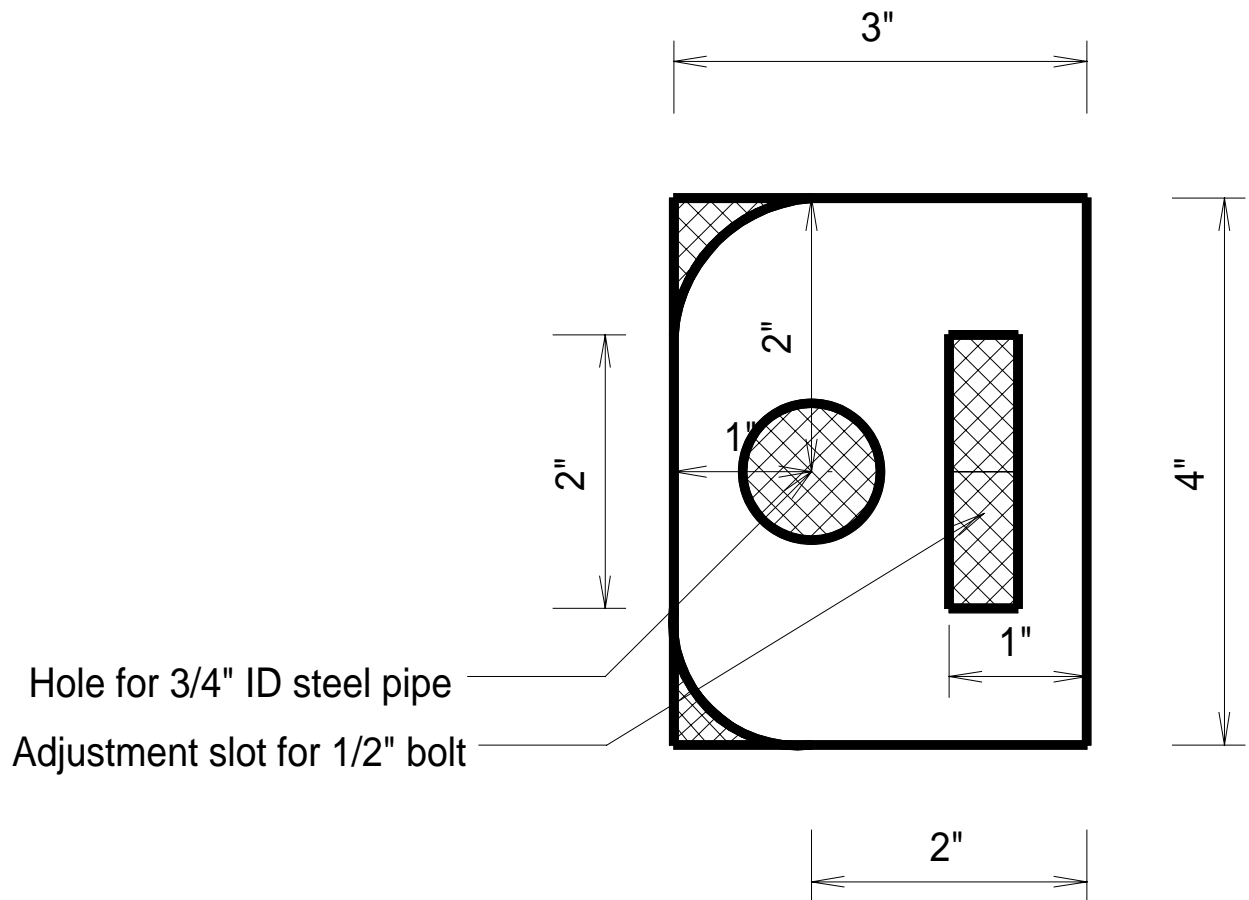

1. What shade lens is suitable for oxy-acetylene welding?
  - 1a.
  - 1b.
  - 1c.
  - 1d.
2. Which tank contains acetylene?
  - a. 1
  - b. 2
3. Which tank contains a burstable disc?
  - a. 1
  - b. 2

4. Which tank contains fusible plugs?  
a. 1  
b. 2
5. What are the dimensions (to the nearest 1/8 inch) of the piece of steel labeled #5?  
\_\_\_\_\_ x \_\_\_\_\_ x \_\_\_\_\_
6. What is the size of the tip labeled #6?
7. Use the Smith Welding table to determine which torch attachment would be best suited for welding the steel marked item 7 with an oxyacetylene welder?  
7a.  
7b.  
7c.  
7d.
8. Examine the regulator tagged number 8. Is the acetylene pressure set properly to cut the metal provided?  
8a. yes  
8b. No \_\_\_\_\_ (if no, you **MUST** write in the correct pressure)