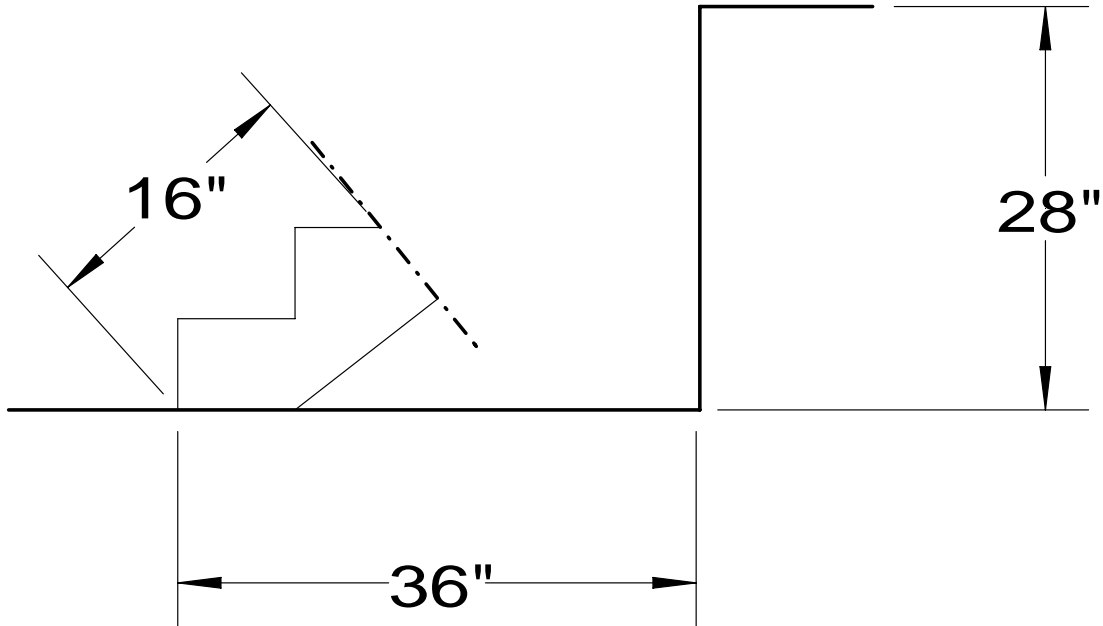



**Diagram and Information:**

The stairs need to rise 28 inches and span 36 inches. The step tread will be constructed from 1½" thick stock.



**Note: The above stair stringer sketch is to show what is to be laid out. The dimensions used to show layout are approximate and for illustration only. (15 points)**

**HEAT BOX (5 points)**

Using the digital thermometer, determine which side (A, B, C, D) of the box is the most insulated. Circle the letter corresponding to the side you select.

- A.    B.    C.    D.

## Determining a Material List (20 points)

You are building a 40 ft x 60 ft pole barn. 6x6 (6" x 6") posts are placed 10' o.c. along the length of all four walls. Horizontal 2x6 (2" x 6") girts are placed 2' o.c. from the bottom to the top of all four 8' high walls. Metal sheets 38" wide and 8' long will be used for siding. The metal sheets require a 2" overlap. Trusses span the 40' width, have a 4:12 roof pitch, and are fastened to the top of each sidewall post. 2x4 (2" x 4") roof purlins are placed on edge at 2' o.c. along the top chord of the trusses to fasten the metal roof. Schematics are provided on the following pages showing some of the construction details for this building.

- 1) How many 12' long 6x6 posts are required to construct this building?
- 2) Calculate how many running feet of 2x6's are required for girts on all four walls. Assume no doors are present for your calculations.
- 3) Calculate how many sheets of metal siding are required to cover one 60' long side wall.
- 4) Calculate how many running feet of 2x4's are required as roof purlins.

Below is given the floor plan of building showing post locations.

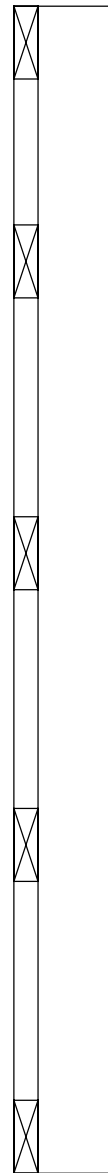
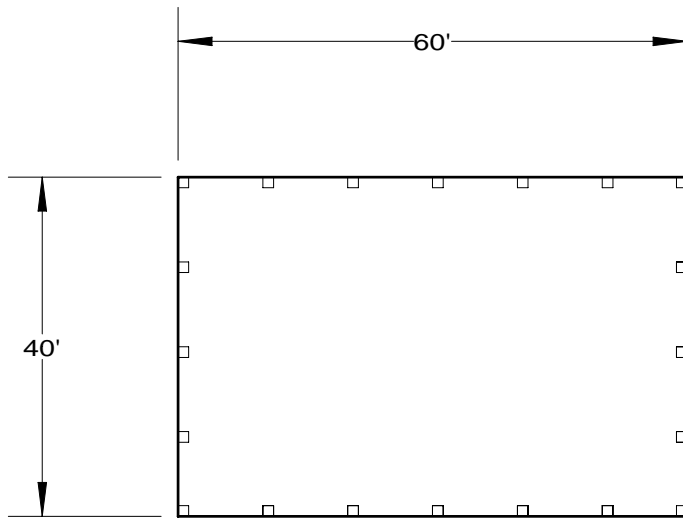

Above is a detail giving the 8' high wall construction.

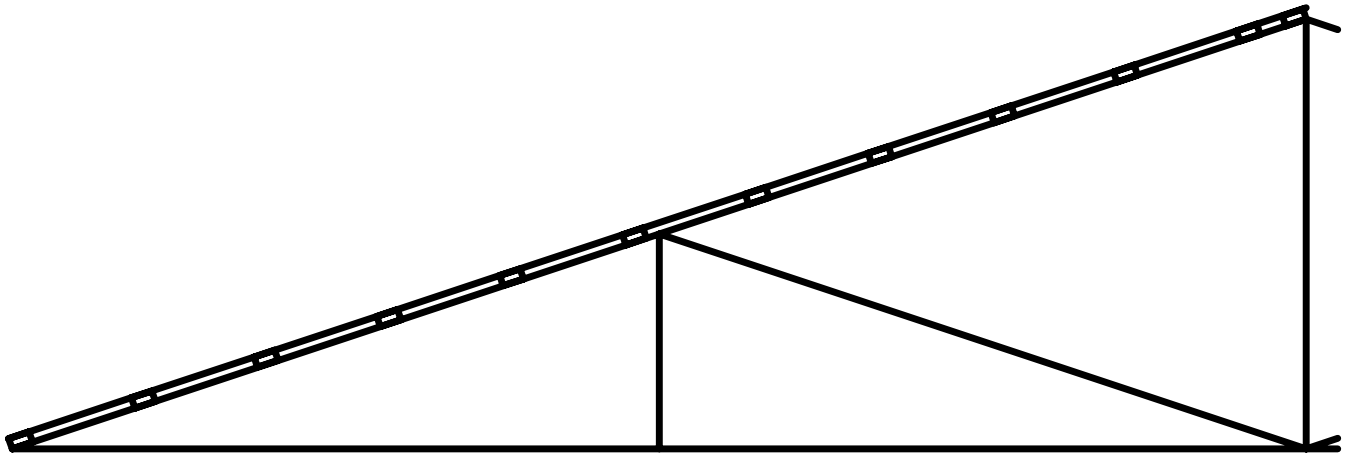

Above is sketch showing approximate purlin spacing on half of truss. Top chord is on a 4:12 pitch and truss spans a total of 40 feet.