



2006 State Competition  
 FFA Agricultural Mechanics Contest  
 University of Missouri  
 50 points

Contestant # \_\_\_\_\_  
 Contestant Name \_\_\_\_\_  
 Chapter \_\_\_\_\_

## Concrete & Plumbing

**Plumbing -Skill:** Assemble the PVC pipe as shown below

**Materials needed:** 1/2" PVC pipe, 1/2" cap, 1/2" coupler, hacksaw, PVC pipe cleaner, primer, and glue.

**Directions:**

1. Secure a 1/2" PVC pipe coupler.
2. Cut a piece of 1/2" PVC pipe so that it extends 1 1/2" out of the coupler as indicated below.
3. Place the 1/2" coupler on the PVC pipe then clean, prime and glue the PVC pipe leaving a clean, strong joint.
4. Cut a piece of 1/2" PVC pipe to create a 1 1/2" spacing between the coupler and the cap.
5. Place the 1/2" cap on the end of the 1/2" PVC pipe then clean, prime and glue the PVC pipe leaving a clean, strong joint.
6. Put a sticker with your name and school name on your pipe, turn in to contest official and continue on second page.

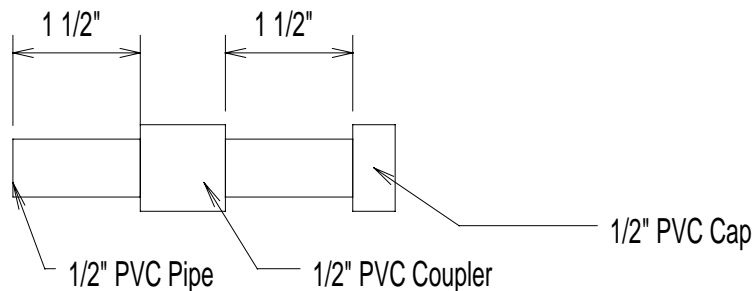

	Points	
	<u>Possible</u>	<u>Earned</u>
1. Neatness, Appearance	5pts.	___
2. Passes 50 psi air test	7pts.	___
3. Correct length	8pts.	___
<b>4. Safety Failure</b>	<b>(-5pts.)</b>	___
 Total from problem solving skill	 20pts.	 ___

**Concrete problems (15pts): Show Work for Full Credit!**

Scenario: You are adding a 40' x 60' barn to your dairy operation. There will be 2-10' wide storage bays in one end of the building (Fig. 1). The following concrete footing is to be poured around the entire perimeter of the facility and between the bays (Fig. 2). **Note: The fronts of the bays will be open.**

**Fig. 1  
Building**

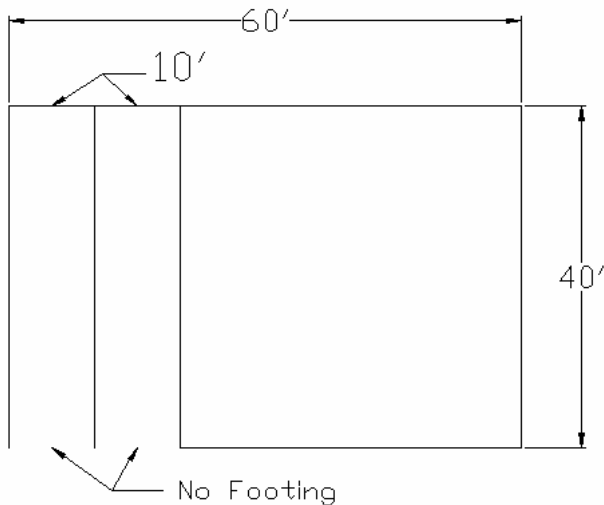

**Fig. 2  
Footing**

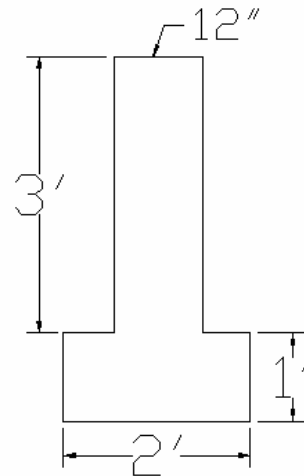

1. What is the cross-sectional area of the concrete footing (Fig. 2) in feet<sup>2</sup>? (3 pts)
2. If the footing (Fig. 2) is poured around the entire perimeter of the barn (Fig. 1) (except for the fronts of the two bays) and between the bays, how many cubic yards of concrete are needed. **Note: Assume a 10% waste factor.** (4 pts)
3. What is the capacity (in bushels) of one bay assuming a height of 7' and leveled off at the top? **Note: 1 bushel = 1.25 feet<sup>3</sup>.** (3 pts)

**Use Table 1 to answer questions 4 and 5.**

Table 1 gives psi/100' of pipe. Multiply the psi loss value shown by the total length of the pipe section, and then divide the product by 100.

$$\frac{\text{Value} * \text{Length}}{100} = \text{psi loss}$$

Table 1	Polyethylene Pipe Size (Inches)				
	¾	1	1 ¼	1 ½	2
<b>Flow in GPM</b>					
1	0.12	0.04	0.01	0.00	0.00
5	2.44	0.76	0.20	0.09	0.03
10	8.82	2.73	0.72	0.34	0.10
15	21.07	6.51	1.71	0.81	0.24
20	31.85	9.84	2.59	1.22	0.36
30	67.50	20.85	5.49	2.59	0.77

4. What would be the pressure loss (psi/ft) for a waterer in the barn that requires 10 GPM? The system uses 1" polyethylene pipe and is 500' from the source. (2 pts)
  
5. What size of pipe would be needed for another waterer that requires 20 GPM? The system should be able to water 50 head of cattle. Pressure at the pump is 60 psi and should not drop below 57 psi over the 600' from source to the water (3 pts)

**Plumbing I.D. (15 pts):**

Identify the correct names of the labeled plumbing components and match them with the description that best fits the component. Use the following list and place the corresponding letter with the proper description in the blanks provided. Then circle the proper size or maximum output of the component.

**Plumbing Components:**

- a. Pressure Gage
- b. Flow Meter
- c. Ball Valve
- d. Utility Pump
- e. Gate Valve

**Tool Descriptions:**

- f. Valve in which the flow of a fluid is controlled by a rotating, drilled ball that fits tightly against a resilient (flexible) seat in the valve body.
- g. Compression-type valve in which the flow of water is controlled by means of a circular disk that is forced (compressed) onto or withdrawn from a ring, (seat), surrounding the opening through which water flows.
- h. Valve that controls the flow of fluid moving through the valve by means of a gate-like wedge disk that fits against smoothly machined surfaces, (seats), within the valve body.
- i. Device that measures the volume of water used by a pumping fixture in a given amount of time. Usually expressed in gallons per minute (gpm).
- j. Designed for water transfer applications including; emptying or filling tanks, lawn sprinkling, and drawing water from lakes and ponds.
- k. Measures pressure from the source.
- l. Measures pressure on return side of system.
- m. None of the above- Write in the correct answer in the blank

<u>Name (1pt)</u>	<u>Description (1pt)</u>	<u>Size (1pt) (Circle One)</u>
1.) _____	_____	1 ¼” or 1”
2.) _____	_____	1” or 10 GPM
3.) _____	_____	10 GPM or 25 GPM
4.) _____	_____	¾” or 1”
5.) _____	_____	15 psi or 60 psi